

CAB SUSPENSION



A smoother ride with improved durability

Ride quality matters. When a truck rides better, the driver is happier, healthier and more productive. Cab suspension components are crucial to enhancing driver comfort and reducing fatigue due to long hours behind the wheel. Learn how Power-Packer's cab suspension system enhances driver safety and comfort.

CAB SUSPENSION OVERVIEW FOR UP TO 2,000 LB VERTICAL LOAD

SAFETY & COMFORT

Isolate the driver and cab from vibration damage and shock, improving driver safety and comfort, while decreasing cab wear and tear. Cab suspension is adjustable and available for driver and passenger sides of the vehicle.

INTEGRATION OPTIONS

Integrate latches with suspension assemblies for one complete system.

DESIGN OPTIONS

Cab suspension is available with and without rubber dampers. Rubber dampers are ideal for rough duty cycles, because the arm limits air shock travel, increasing the life cycle in rougher terrain.



CAB SUSPENSION

A bolt-on air cab suspension system that is easily integrated into your next application. With the option to place on either the driver or passenger side, our cab suspension creates a smooth ride for passengers, while eliminating the wear and tear on your vehicle. Other features and benefits include:

- 120 psi max operating pressure
- 2,000 lb. load capacity at 100 psi
- 1.7 in. vertical suspension travel

Why Choose Power-Packer Cab Suspension

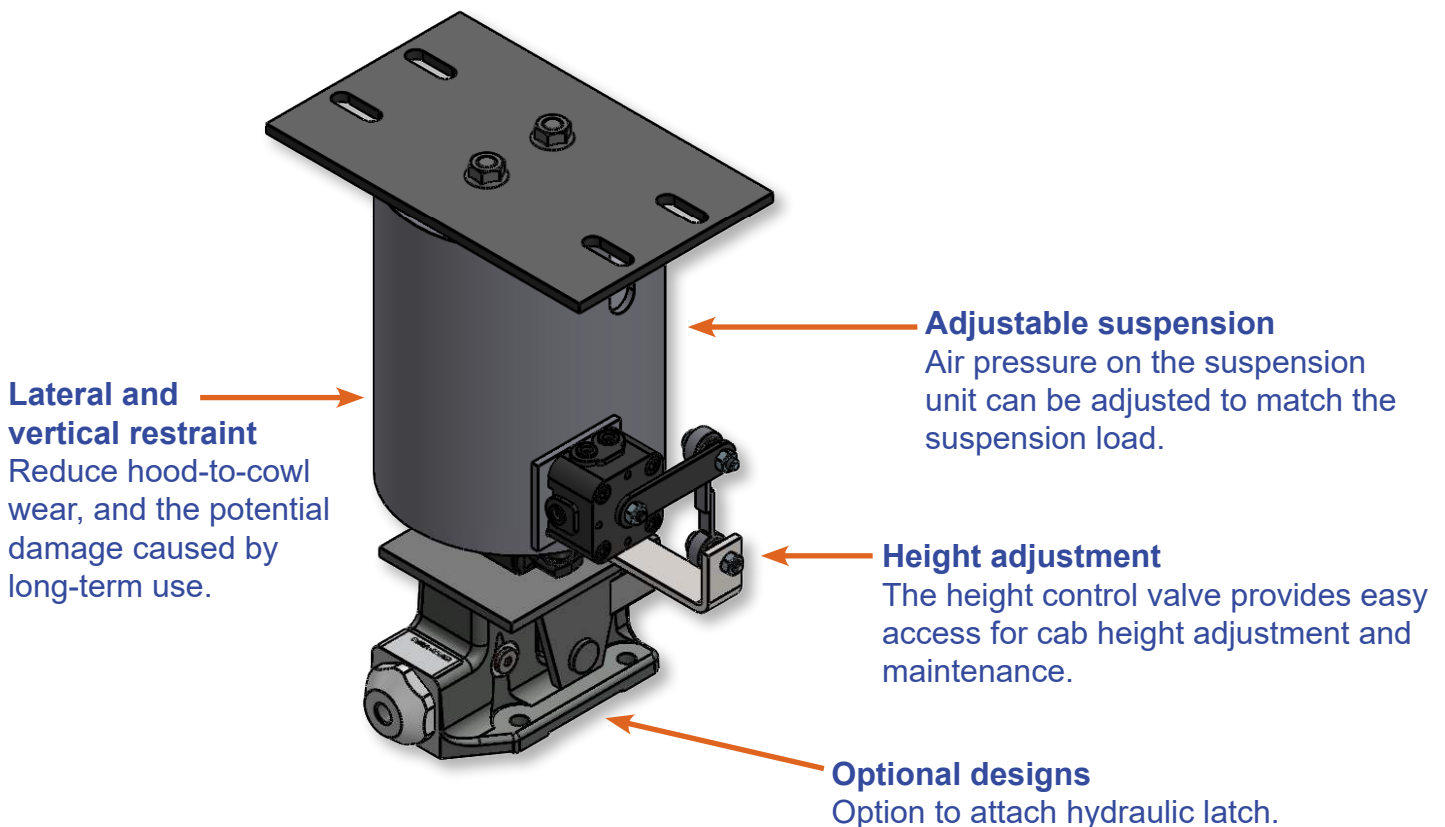

CAB SUSPENSION

Cab Suspension										
Part #	Height		Mounting Width		Mounting Length		Max Operating Pressure		Load Capacity at 100 psi (kN) at 6.9 bar	
	in.	mm	in.	mm	in.	mm	psi	bar	lbs.	kg
Driver										
AS50101331	11.7	297.2	2.25	57.2	6.7-8.5	170.2-215.9	120	8.27	2000	907.18
KA5089	11.7	297.2	2.25	57.2	6.7-8.5	170.2-215.9	120	8.27	2000	907.18
AS50101335	11.7	297.2	2.25	57.2	6.7-8.5	170.2-215.9	120	8.27	2000	907.18
AS50101319	11.7	297.2	2.25	57.2	6.7-8.5	170.2-215.9	120	8.27	2000	907.18
PP938900-2G	11.7	297.2	2.25	57.2	6.7-8.5	170.2-215.9	120	8.27	2000	907.18
Passenger										
AS50101332	11.7	297.2	2.25	57.2	5.3-6.9	134.6-175.3	120	8.27	2000	907.18
KA5090	11.7	297.2	2.25	57.2	5.3-6.9	134.6-175.3	120	8.27	2000	907.18
AS50101336	11.7	297.2	2.25	57.2	5.3-6.9	134.6-175.3	120	8.27	2000	907.18
AS50101320	11.7	297.2	2.25	57.2	5.3-6.9	134.6-175.3	120	8.27	2000	907.18
PP939900-2G	11.7	297.2	2.25	57.2	5.3-6.9	134.6-175.3	120	8.27	2000	907.18
KA5083	11.7	297.2	2.25	57.2	6.7-8.5	170.2-215.9	120	8.27	2000	907.18
KA5084	11.7	297.2	2.25	57.2	6.7-8.5	170.2-215.9	120	8.27	2000	907.18
KA5087	11.7	297.2	2.25	57.2	6.7-8.5	170.2-215.9	120	8.27	2000	907.18
KA5088	11.7	297.2	2.25	57.2	6.7-8.5	170.2-215.9	120	8.27	2000	907.18

