



#TechTipTuesday

MAINTENANCE STEPS: Repairing the seals on your stabilization legs

There is an easy process to repair the leg seals so you don't need to replace stabilization legs. Follow these steps based on the size of your stabilization legs, and remember to always wear proper personal protective equipment:

3-INCH STABILIZATION LEGS

KIT# 200080

1. REPLACING LEG SEALS

- A. Fully retract leg(s).
- B. Remove leg from mounting on trailer or vehicle.
 1. Loosen hose connections going from ports "A," "B" and "R."
 2. Using a 1/8-inch Allen wrench, slowly turn plug (12) to bleed trapped pressure from the cylinder base side. Remove plug completely when pressure is bled down.
- C. Remove the shoe by removing cotter pin (26) and pin (33).
- D. Loosen the tube nuts (28) approximately two turns to bleed pressure.
- E. Place leg on a table or horizontal surface and remove snap ring (25) using a Waldes snap ring pliers No. S-6700 or equivalent.
- F. Hang legs upside down using a hoist, and use shoe pin hole to attach chain or cable. Tap on mounting plate with a wood block or hammer to force the piston rod assembly to slide within the cylinder barrel. Continue to tap until the rod guide (23) and piston assembly (18, 27 and 20) can be pulled out of the barrel.
- G. Place rod piston assembly (18 and 27) and rod guide on clean table.
- H. Remove rod guide (23) from the rod by tapping it over the rod end.
- I. Remove piston retainer snap ring (13) using Waldes pliers No. S-6600 or equivalent. Tap piston off of rod using a rubber cap mallet.

2. INSTALLATION OF NEW SEALS AND CYLINDER ASSEMBLY

- A. Rod guide – Remove wiper, rod seal, wear ring, back-up ring and o-ring (31, 30, 24, 22 and 21 respectively). Install new seals.
 1. Wiper lips (31) should be facing outward.
 2. Shaft seal lips (30) facing inward.
 3. Work in wear ring (24) with screwdrivers.
 4. Install back-up ring (22) to outside of groove. Radius portion must face inward (touching o-ring).
 5. Install o-ring (21) as shown.
 6. Lubricate all seals thoroughly.
- B. Piston rod assembly
 1. Remove the piston seal, wear ring, back-up rings and o-ring (17, 15, 14 and 16).
 2. Install new piston seal (17) (similar to installing a tire on a bicycle wheel).

3. Install new wear ring (15).
4. Install new back-up rings and o-ring(14 and 16) on rod. The back-up rings sandwich the o-rings with the curved portion touching the o-ring on both sides.

Lubricate all seals and rod thoroughly, tap piston over rod until bottomed on the rod shoulder. Install new snap ring (13) with Waldes pliers No. S-6600.

C. Cylinder assembly

1. With cylinder barrel resting on its head (upside down), lubricate the opening of the cylinder barrel. Drop the piston rod assembly straight and gently into the barrel. Tap drive into approximately full retraction.
2. Lubricate the round end of the rod and gently tap the rod guide fully into the barrel. Use a brass or bronze drift to tap around the rod guide until it is bottomed out, then a new snap ring (25) can be installed using Waldes pliers No. S-6600.
3. Install new o-ring (1) on plug (12) and fully insert plug (12).
4. Install leg(s) on equipment, reversing the steps in the leg seal replacement section.
5. After all hose connections are complete, cycle legs up and down (full stroke, two or three times, to purge trapped air).

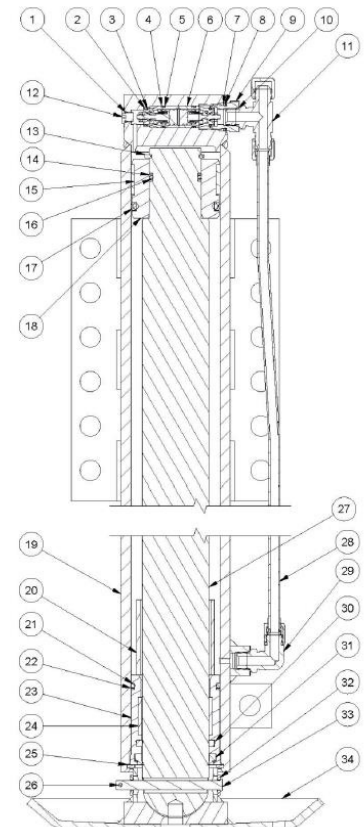

#TechTipTuesday

3.5-INCH STABILIZATION LEGS

Kit# 101086

4-INCH STABILIZATION LEGS

Kit# 100422

DISASSEMBLY/ASSEMBLY PROCEDURE

When disassembling and reassembling the stabilization leg, make sure to keep all parts clean to prevent them from being damaged.

- A. To remove leg from equipment, make sure no weight is being supported by legs. Have legs slightly extended from full retract position to relieve any internal pressure in legs. Disconnect the hoses from the leg. You may wish to mark which hose goes to each port. Remove the leg.
- B. Remove the lock valve (1) from the leg by screwing counter clockwise. If you need to only repair the lock valve, remove it from the leg while it's still on the equipment, but only if you have a minimum of 2 inches of clearance.
- C. Remove o-rings and back-up washers (2, 3, 4 and 5). Using a snap ring pliers, remove snap ring (6). Loosen hex screw (8).
- D. Lift well tube (19) off lower leg assembly. Lift piston rod (18) to gain access to the top of the cylinder head (17).
- E. Remove four hex screws (10). Lift cylinder head retainer (11). A wire or rubber band may be used to hold the cylinder head retainer to the sprocket near the top of piston rod, out of the way.
- F. Using a small, flat screwdriver, carefully remove spiral retaining ring (12). Lift piston rod assembly out of cylinder tube (28).
- G. Using a large snap ring pliers, remove heavy-duty snap ring (26) or remove the set screw (30). Remove the piston (27), cylinder head (17), retaining ring (12) and cylinder head retainer (11).
- H. Remove all seals and wear rings. Clean all parts. Inspect all bearing surfaces for scratches, nicks or other defects, and replace if necessary. Replace all wear rings, and lightly lubricate all seals before installing on legs.
- I. Carefully reassemble the leg in reverse order as described above. Where applicable, torque the piston (27) to 40 to 50 foot pounds. Apply two drops of Loctite® 277 or equivalent to set screw (30) and torque to 50 inch pounds.
- J. Return leg to equipment and reconnect all hoses. Apply grease to grease fittings (21), and cycle legs fully several times to bleed air from system. Check oil level as described in the maintenance section of the manual.

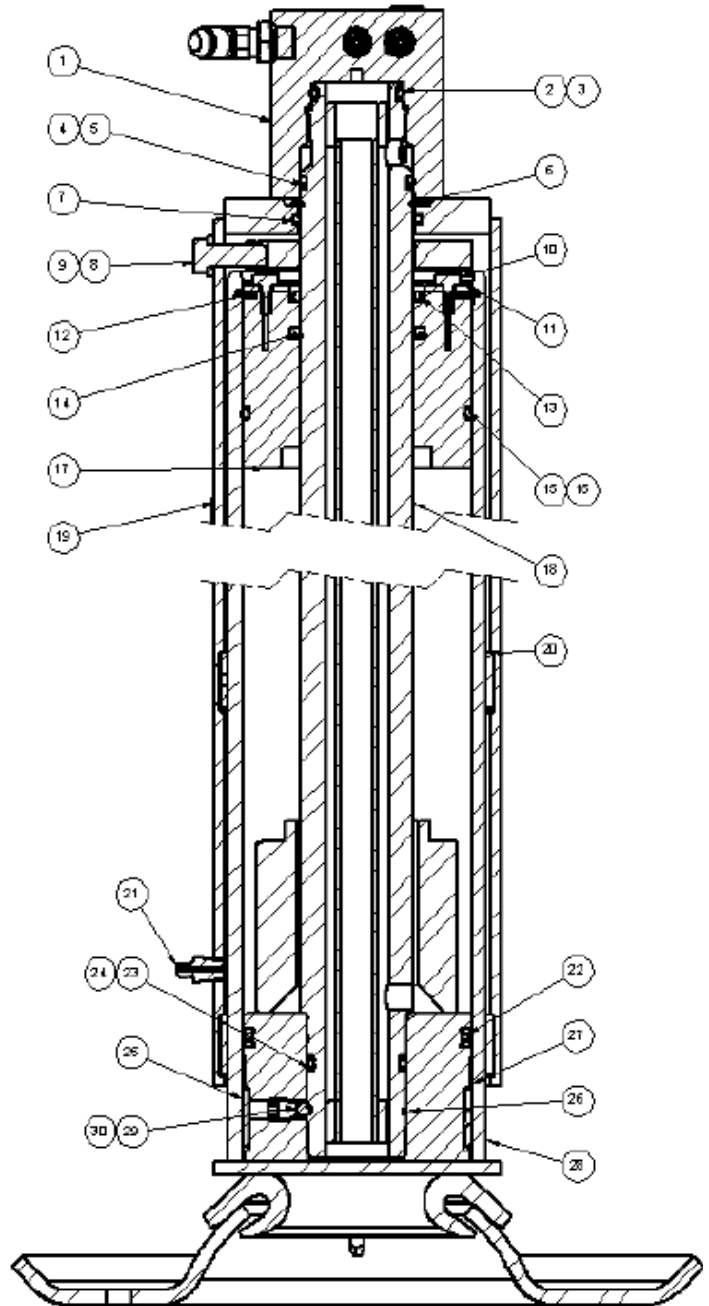

#TechTipTuesday

5-INCH STABILIZATION LEGS

Kit# 300508

This kit contains the necessary soft parts (seals) and associated parts to repair one, 5-inch stabilization leg:

- A. With the pump off, cycle the valve to relieve any pressure.
- B. Disconnect the hydraulic lines from the leg, and remove the leg from your equipment.
- C. Remove the lock valve (A) by removing the four H.H.C.S. (B).
- D. Take the shoe off by removing H.H.C.S. (C).
- E. Remove the six H.H.C.S. (D) and lift the cylinder tube (E) off the well tube (F).
- F. Lift the piston rod assembly (G) away from the cylinder tube (E), then remove the rod guide (H) from the cylinder tube (E) by unscrewing it.
- G. Lift the piston rod assembly (G) out of the cylinder tube (E).
- H. Remove wear ring (7) from piston (1), and screw piston off using a 7/16-course bolt in the threaded hole. Clean and inspect all metal parts, and replace any damaged parts.
- I. Replace all seals and lightly coat with grease.
- J. Put Loctite® 277 or equivalent on threaded parts.
- K. Assemble leg in reverse order.
- L. Coat bottom of lock valve and top of cylinder head with anti-seize.
- M. Place gasket between the leg and lock valve, verify the two o-rings are in place on the bottom of the lock valve, and remount lock valve to leg.
- N. Remount leg to equipment.
- O. Follow fill and bleed procedure to remove air from the system.

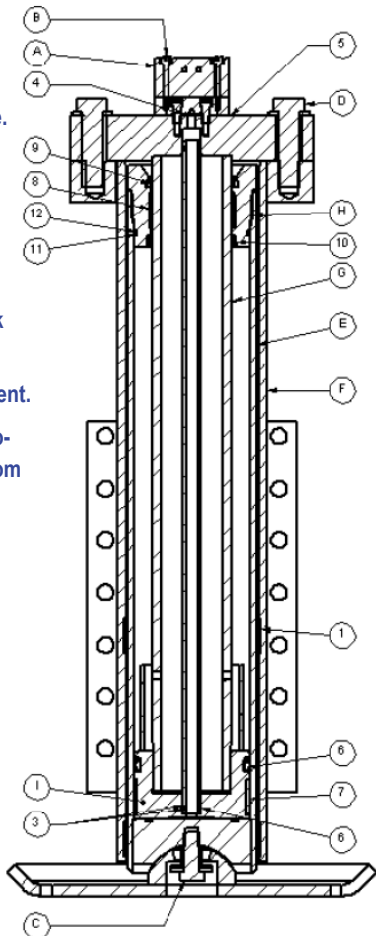

6-INCH STABILIZATION LEGS

Kit# 300086

This kit contains the necessary soft parts (seals) and associated parts to repair one, 6-inch stabilization leg. Some items will not be used for a particular leg, but are included to form a universal kit:

- A. With the pump off, cycle valve to relieve any pressure.
- B. Disconnect hydraulic lines from leg. Remove leg from equipment.
- C. Remove lock valve by removing the four bolts (A).
- D. Remove two bolts (C and D).
- E. Remove three bolts (B) from leg and lift well tube off of cylinder tube.
- F. Lift piston rod assembly, then remove the six hex head screws (E) and the snap ring (8).
- G. Lift the piston rod assembly out of cylinder tube.
- H. Remove the wear ring (7) from the piston, and screw the piston rod off using a 7/16-inch course thread bolt.
- I. Clean and inspect all metal parts and replace any damaged parts.
- J. Replace all seals and lightly coat with grease.
- K. Assemble leg in reverse order.
- L. Coat the bottom of the lock valve and top of cylinder head with anti-seize.
- M. Place gasket between the leg and the lock valve, verify the two o-rings are in place on the bottom of the lock valve, and remount the lock valve to the leg.
- N. Remount leg to equipment.
- O. Follow fill and bleed procedure to remove air from the system.

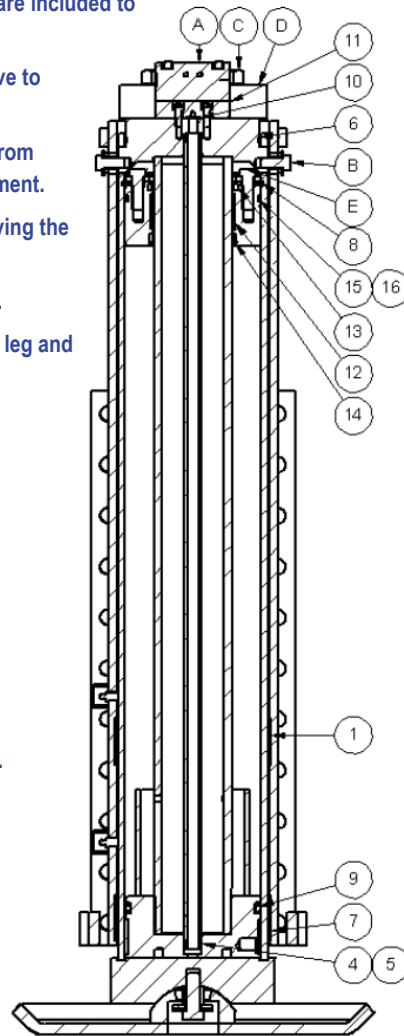

Questions about the maintenance process or need help finding a local repair center? Contact our Customer Service team at info@powerpacker.com for more information.

***NOTE THAT THIS PROCESS APPLIES ONLY TO POWER-PACKER PRODUCTS MANUFACTURED IN NORTH AMERICA.**